

DOT 160x17 P SUPERFAST



PORTABLE · DOT PEEN MARKING

- **Portable dot peen marking unit with maximum speed in minimum dimensions, especially designed to mark pieces in any area and position.**

ADVANTAGES

- **Ergonomic and lightweight**, it facilitates access to any position and handling for the user.
- **Built-in supports** to properly secure and have appropriate distance between the marking unit and the piece, **thereby guaranteeing mark quality.**
- **Maximum marking speed**, for all kinds of materials and hardnesses up to 62HRC.
- **Minimum dimensions**, making this marking unit **the smallest and fastest on the market.**
- Highly **robust and long-lasting**, thanks to the high quality of its components.

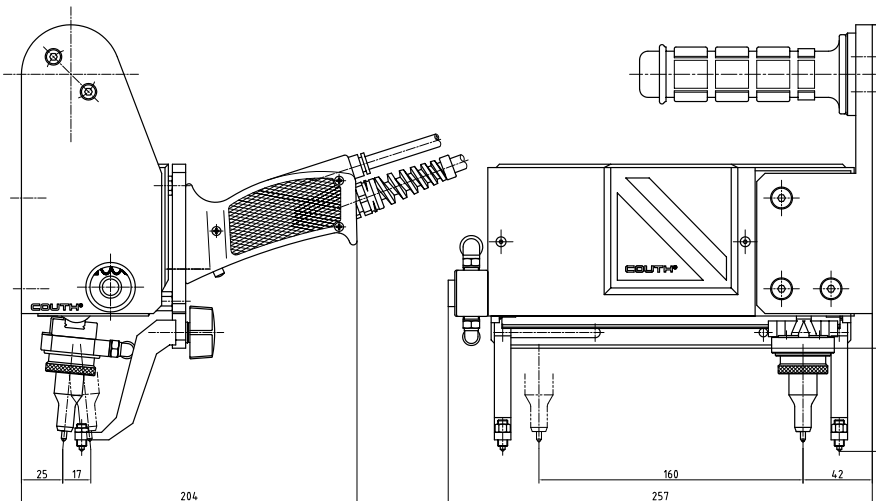

Area	Dimensions (mm)			Weight
	X x Y	Width	Depth	
160 x 17	257	204	260	4,6

CHARACTERISTICS

- 160 x 17 mm marking area (with 160 x 25 mm option).
- Speed up to 16 characters/second.
- 6-bar air pressure.
- Hardness of materials to mark up to 62HRC.
- Wide range of characters, from 0.1 mm to complete area.
- Marking alphanumeric codes, logotypes, DATAMATRIX™, QR codes, etc.
- Different marking head types, depending on marking needs: pneumatic (N7, N10, N14, N20) and electric (S2, S6).
- Optional protection system that is easy to assemble and disassemble.
- 2,5 meter robotics cable, with customisation possibilities.
- Connection with COUTH control unit (see technical file for more information).
- PC edition software.